

FORKLIFTS

AUSTRALIA

HIRE

SALES

SERVICE

LEASE

TRANSPORT

F Series

DIESEL

GAS/LPG



2.0T - 3.5T FORKLIFTS



WA

NT

QLD

NSW

VIC

SA

forkliftsaustralia.net.au

☎ 13 8000

F Series 2.0T - 3.5T

[DIESEL](#)[GAS/LPG](#)

The F Series, UN Forklift's latest internal combustion model, delivers a fresh design with exceptional performance, offering a durable and efficient material handling solution.

Built for demanding environments, it combines advanced technology with a 2.0T-3.5T lifting capacity, making it ideal for heavy-duty applications.



Images are for demonstration purposes only.



Engine & Performance

ENGINE

The F Series, powered by Mitsubishi 4EG and Kubota engines, delivers superior performance with exceptional reliability, power, and efficiency in any environment.

HYDRAULIC SYSTEM

The F Series boasts a hydraulic transmission, 50L fuel tank, 19 km/h travel speed, 510 mm/sec lift speed, and 20% gradability, ensuring excellent performance on tough terrains and heavy-duty tasks.



IMPROVED DESIGN

The F Series features a spacious cabin with a suspended seat, adjustable steering, and a ratchet handbrake for operator comfort and ease. Wide foot space and a low pedal height improve accessibility, while detachable side panels and a large engine hood ensure fast maintenance. With a 510 mm/sec lift speed and 20% gradability, it delivers efficiency and reliability for demanding tasks.



Safety Features

DURABILITY AND PROTECTION

A stamped overhead guard, reinforced splash guard, and streamlined body enhance durability and reduce drag, ensuring long-lasting performance in demanding environments.

ADVANCED TECHNOLOGY

Equipped with an interactive dashboard for real-time monitoring, the F Series includes a next-generation LED lighting system and a load-sensing steering system for smooth, responsive handling.



ENHANCED MAST DESIGN

The F Series features a narrow-groove steel mast, reducing weight and improving visibility for more efficient operation.

IMPROVED VISIBILITY

A standard panoramic mirror expands the field of view, while a CE-certified beacon enhances visibility in low-light conditions, promoting safer operation.

WEATHER-RESISTANT FEATURES

Waterproof connectors ensure reliable performance in all weather conditions, reducing downtime and maintenance needs.

OPERATOR SAFETY

The F Series includes an OPS (Operator Presence System) that prevents unintended startup, ensuring the operator is securely positioned before operation.



HIRE

SALES

SERVICE

LEASE

TRANSPORT

Diesel Models



FD20T



FD20T



FD25T



FD25T



FD30T



FD30T

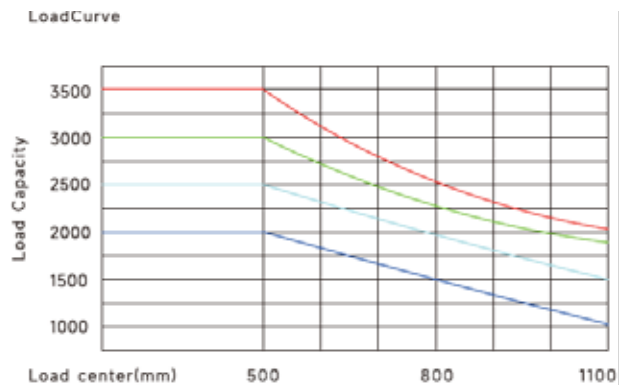
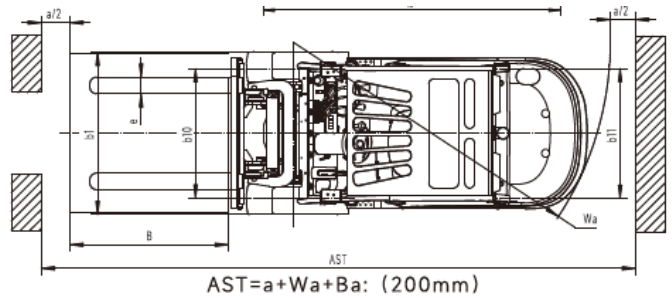
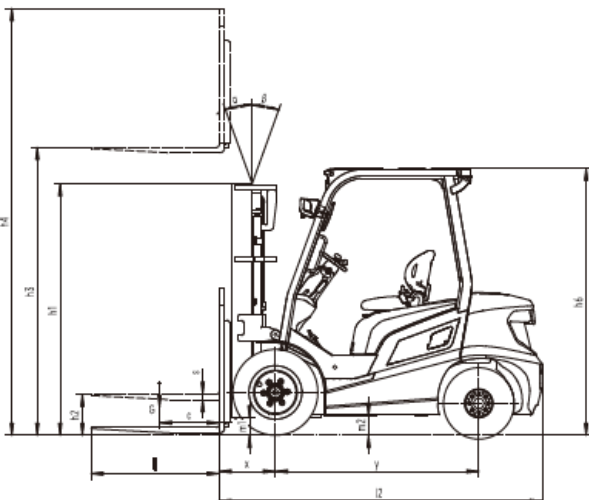

Images are for demonstration purposes only.

HIRE

SALES

SERVICE

LEASE

TRANSPORT

Mast & Rated Capacities

2T to 2.5T Forklifts

Mast Type	Mast Name	Fork Height Max. (mm)	Load Capacity (kg)		Overall Height (mm)			Free Lift (mm)		Tilt Angle (Single)
			2.0T	2.5T	Lowered	Extended		Without Backrest	With Backrest	
						Without Backrest	With Backrest			
						2.0T/2.5T		2.0T/2.5T		
2-Stage Wide View Mast	M270	2700	2000	2500	1920	3255	3718	1300	857	6-12
	M300	3000	2000	2500	2070	3605	4068	1470	1007	6-12
	M330	3300	2000	2500	2220	3955	4418	1620	1157	6-12
	M350	3500	2000	2500	2320	4105	4568	1720	1257	6-12
	M370	3700	2000	2500	2420	4255	4718	1800	1357	6-6
	M400	4000	2000	2500	2670	4605	5068	2000	1607	6-6
3-Stage Full Free Wide View Mast	TFM400	4000	2000	2500	1945	4607	5070	1300	885	6-6
	TFM430	4300	1850	2200	2045	4907	5370	1400	985	6-6
	TFM450	4500	1700	2000	2095	5107	5570	1498	1035	6-6
	TFM470	4700	1600	1900	2145	5307	5770	1548	1085	6-6
	TFM500	5000	1400	1500	2245	5607	6070	1648	1185	6-6
	TFM550	5500	1100	1200	2445	6107	6570	1800	1385	3-6
	TFM600	6000	800	850	2645	6607	7070	2000	1585	3-6
	TFM650	6500	500	550	2895	7107	7570	2200	1835	3-6
	TFM700	7000	100	150	3095	7607	8070	2300	2035	3-6

3.0T to 3.5T Forklifts

Mast Type	Mast Name	Fork Height Max. (mm)	Load Capacity (kg)		Overall Height (mm)			Free Lift (mm)		Tilt Angle (Single)
			3.0T	3.5T	Lowered	Extended		Without Backrest	With Backrest	
						Without Backrest	With Backrest			
						3.0T/3.5T		3.0T/3.5T		
2-Stage Wide View Mast	M300	3000	3000	3500	2060	3641	4060	125	125	6-12
	M330	3300	3000	3500	2210	3941	4360	125	125	6-12
	M350	3500	3000	3500	2310	4141	4560	125	125	6-12
	M370	3700	3000	3400	2410	4341	4760	125	125	6-6
	M400	4000	2950	3250	2510	4641	5060	125	125	6-6
	M430	4300	2800	3100	2760	4941	5360	125	125	6-6
	M450	4500	2600	2900	2860	5141	5560	125	125	6-6
	M470	4700	2500	2800	2960	5341	5760	125	125	6-6
	M500	5000	2200	2400	3160	5641	6060	125	125	6-6
3-Stage Full Free Wide View Mast	TFM400	4000	3000	3000	1960	4641	5060	1280	860	6-6
	TFM430	4300	2800	3000	2060	4941	5360	1380	960	6-6
	TFM450	4500	2600	2800	2160	5141	5560	1480	1060	6-6
	TFM480	4800	2300	2500	2260	5441	5860	1580	1160	6-6
	TFM500	5000	2100	2300	2310	5641	6060	1630	1210	6-6
	TFM550	5500	1650	1800	2510	6141	6560	1830	1410	3-6
	TFM600	6000	1200	1300	2710	6641	7060	2030	1610	3-6

[HIRE](#)
[SALES](#)
[SERVICE](#)
[LEASE](#)
[TRANSPORT](#)

Specifications

[DIESEL](#)

2.0T to 3.5T Forklifts

Manufacturer		UN							
Model		FD20T-XJM3	FD20T-XJV2	FD25T-XJM3	FD25T-XJV2	FD30T-XJM3	FD30T-XJV2	FD35T-XJV2	
General	Power Type	Diesel							
	Rated Load Capacity	Q(kg)	2000	2500	3000	3500			
	Load Centre	C(mm)	500	500	500	500			
	Rated Lift Height	H3(mm)	3000	3000	3000	3000			
Characteristics & Dimensions	Free Lift Height	H2(mm)	140	140	125	150			
	Fork Size (LxWxT)	mm	1070x120x140				1070x125x45		1070x125x50
	Mast Tilt Angle	deg	6 °/12 °	6 °/12 °	6 °/12 °	6 °/12 °	6 °/12 °	6 °/12 °	
	Fork Overhang	X1(mm)	460	460	470	480			
	Ground Clearance	H7(mm)	110	110	125	125			
	Length to Face of Fork	L1(mm)	2630	2630	2700	2780			
	Overall Width	B1(mm)	1170	1170	1220	1225			
	Mast Lowered Height	H1(mm)	2055	2055	2060	2070			
	Mast Extended Height	H4(mm)	4070	4070	4150	4070			
	Overhead Guard Height	H5(mm)	2215	2215	2190	2235			
	Turning Radius	Wa(mm)	2365	2365	2450	2500			
	Min. Pallet aisle width	Ast(mm)	4120	4120	4120	4255			
	Performance	Travel Speed (No Load)	km/h	19	19	19	19		
		Lifting Speed (Full Load)	mm/sec	510	510	430	400		
Lowering Speed		mm/sec	No Load ≥ 300 Full Load ≤ 600				No Load ≥ 300 Full Load ≤ 600		
Max Drawbar Pull		KN	17/14.5				26/21		
Max Gradeability (Full Load)		%	20						

[HIRE](#)
[SALES](#)
[SERVICE](#)
[LEASE](#)
[TRANSPORT](#)

Model			FD20T-XJM3	FD20T-XJV2	FD25T-XJM3	FD25T-XJV2	FD30T-XJM3	FD30T-XJV2	FD35T-XJV2	
Chassis	Tyre (Front x2)	mm	7.00-12-12PR				28x9-15-12PR			
	Tyre (Rear x2)	mm	6.00-9-10PR				6.50			
	Front Tread	B2(mm)	970		970		1000		1000	
	Rear Tread	B3(mm)	980		980		980		980	
	Wheelbase	Y(mm)	1650		1650		1700		1700	
Weight	Total Weight	kg	3620		3860		4460		4775	
	Front Axle Weight Distribution (Full Load)	kg	5058		5724		6714		6997	
	Rear Axle Weight Distribution (Full Load)	kg	562		636		746		777	
	Front Axle Weight Distribution (No Load)	kg	1450		1545		1784		1910	
	Rear Axle Weight Distribution (No Load)	kg	2170		2315		2676		2865	
Battery	V/Ah	12/90								
Engine Model		D04EG	V2403	D04EG	V2403	D04EG	V2403	D04EG		
Engine Manufacturer		mitsubishi	KUBOTA	mitsubishi	KUBOTA	mitsubishi	KUBOTA	mitsubishi		
Rated Output/rpm	kw	36/2250	42.6/2400	36/2250	42.6/2400	36/2250	42.6/2400	36/2250		
Rated Torque/rpm	N-m	177/1800	195.6/1500	177/1800	195.6/1500	177/1800	195.6/1500	177/1800		
No. of Cylinders		4								
Bore x Stroke	mm	94 x 120	87 x 102.4	94 x 120	87 x 102.4	94 x 120	87 x 102.4	94 x 120		
Displacement	cc	3331	2434	3331	2434	3331	2434	3331		
Fuel Tank Capacity	L	50								
Transmission Type		HYDRAULIC								
Transmission Stage		1/1								
Operating Pressure	Mpa	18.5								

FORKLIFTS **AUSTRALIA**

HIRE

SALES

SERVICE

LEASE

TRANSPORT

ABOUT US

Forklifts Australia delivers top-quality forklifts and material handling solutions with a reputation for excellence, reliability, and customer satisfaction. With an extensive fleet, we provide a single point of supply for all your forklift and specialist equipment needs, backed by expert advice and exceptional service.

ATHENA



OUR DIFFERENCE

EXTENSIVE RANGE

We stock equipment from world-leading brands like UN Forklift, Kalmar, JCB, Manitou, Merlo, Hyster and more.

20+ YEARS EXPERIENCE

Our team has extensive industry experience so you can be assured you will receive great advice and exceptional service.

COMPLETE SOLUTION

From equipment hire, sales and service, through to transport, we can deliver a complete solution for your project.

OUR LOCATIONS

WESTERN AUSTRALIA

Perth
Kalgoorlie
Karratha
Port Hedland
Newman

QUEENSLAND

Brisbane

SOUTH AUSTRALIA

Adelaide

NEW SOUTH WALES

Sydney
Newcastle

VICTORIA

Melbourne

NORTHERN TERRITORY

Darwin

FA-BRO-UN1.5-3.5T-V3

WA

NT

QLD

NSW

VIC

SA

forkliftsaustralia.net.au

☎ 13 8000